



RAM

RAMTRUCKS.COM



RAM

2013 RAM 2500/3500



2013 RAM 2500/3500 HEAVY DUTY

There's only one way to get it done — and that's doing everything the right way. New 2013 Ram 2500/3500 empower you with fluent ease. For 2013, these tough new Ram Heavy Duty pickups have been transformed into beefier, more capable, and more technologically advanced workers than ever. Even the classic Ram job-rated attitude has evolved — giving you new maximum capability without compromise, and further backed with a raft of best-in-class attributes. The work just got easier — because these workers are the strongest in our history. For more, bookmark ramtrucks.com and visit often.

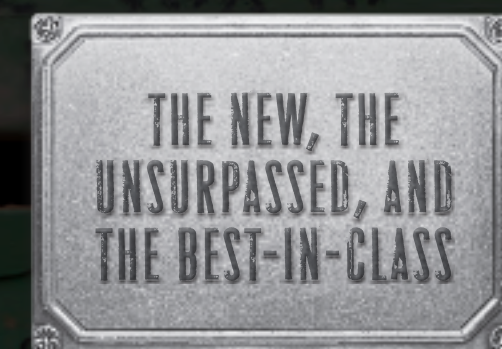

- Best-in-class⁽¹⁾ max GCWR on Ram 3500 — 37,600 lb¹
- Best-in-class⁽²⁾ max GCWR on Ram 2500 — 25,000 lb¹
- Best-in-class⁽¹⁾ max towing capability¹ — Ram 3500
- Best-in-class⁽²⁾ max towing capability¹ — Ram 2500
- Best-in-class⁽¹⁾ available diesel torque — Ram 3500
- Unsurpassed⁽²⁾ available diesel torque — Ram 2500
- Updated frame, steering, front and rear suspensions, and chassis controls on Ram 3500 models
- Unsurpassed⁽¹⁾ max GVWR on Ram 3500 — 14,000 lb¹
- Unsurpassed⁽²⁾ max GVWR on Ram 2500 — 10,000 lb¹
- New 5.7L HEMI[®] V8 gas power — standard for Ram 3500 SRV
- New available AISIN[®] six-speed automatic transmission — Ram 3500
- Class-exclusive⁽³⁾ available six-speed manual transmission — Ram 2500/3500
- New "smart" diesel exhaust brake and electronics
- New standard Electronic Stability Control (ESC)⁽⁴⁾
- Unsurpassed⁽³⁾ 5-Year/100,000-Mile Powertrain Limited Warranty⁽⁵⁾

¹Note: all disclaimers and disclosures can be found at the back of this brochure. ²When properly equipped.



Ram 2500 Crew Cab Big Horn with available 6.7L Cummins® Turbo Diesel shown in Deep Cherry Red Crystal Pearl.
Properly secure all cargo.

6.7L CUMMINS® DIESEL ENGINES

MAXIMUM LOADED TRAILER WEIGHTS (WHEN PROPERLY EQUIPPED)

2500 AUTOMATIC TRANSMISSION														
	AXLE RATIO	GCWR	REGULAR CAB		CREW CAB				MEGA CAB®					
			8' BOX	4x4	6'4" BOX	6'4" RAMBOX®	8' BOX	4x4	6'4" BOX	6'4" RAMBOX				
6.7L CUMMINS TURBO DIESEL I-6 / 68RFE 6-SPEED	3.42	25,000	18,350	17,880	17,950	17,480	17,780	17,270	17,750	17,300	17,570	17,100	17,400	16,950

2500 MANUAL TRANSMISSION														
	AXLE RATIO	GCWR	REGULAR CAB		CREW CAB				MEGA CAB					
			8' BOX	4x4	6'4" BOX	6'4" RAMBOX	8' BOX	4x4	6'4" BOX	6'4" RAMBOX				
6.7L CUMMINS TURBO DIESEL I-6 / 656 6-SPEED	3.42	24,000	17,250	16,800	16,890	16,410	16,720	16,200	16,680	16,230	16,500	16,030	16,330	15,880

WEIGHTS GIVEN IN LB. NUMBERS IN BOLD REFLECT NEW MAX RATINGS.

3500 AUTOMATIC TRANSMISSION																				
	AXLE RATIO	GCWR	REGULAR CAB				CREW CAB				MEGA CAB									
			8' BOX	8' BOX DRW	6'4" BOX	6'4" RAMBOX	8' BOX	8' BOX DRW	6'4" BOX	6'4" RAMBOX	6'4" BOX DRW	8' BOX	8' BOX DRW	6'4" BOX	6'4" RAMBOX	6'4" BOX DRW				
6.7L CUMMINS TURBO DIESEL I-6 / 68RFE 6-SPEED	3.42	25,000	17,940	17,690	17,560	17,360	17,540	17,320	17,410	17,160	17,140	17,360	17,020	16,790	17,270	17,080	17,150	16,990	16,860	16,670
	3.73	27,000		19,560	19,360								19,020	18,790					18,860	18,670
	4.10	30,000		22,560	22,360								22,020	21,790					21,860	21,670
6.7L CUMMINS HIGH OUTPUT TURBO DIESEL I-6 / AISIN® 6-SPEED	3.42	25,000	17,790	17,540			17,390	17,160	17,260	17,000	17,250	17,000			17,120	16,920	16,990	16,780		
	3.42	29,000		21,410	21,200								20,870	20,630					20,710	20,510
	3.73	32,000		24,410	24,200								23,870	23,630					23,710	23,510
	4.10	37,500											29,370	29,130					29,210	29,010
	4.10	37,600			30,010	29,700														

3500 MANUAL TRANSMISSION																				
	AXLE RATIO	GCWR	REGULAR CAB				CREW CAB				MEGA CAB									
			8' BOX	8' BOX DRW	6'4" BOX	6'4" RAMBOX	8' BOX	8' BOX DRW	6'4" BOX	6'4" RAMBOX	6'4" BOX DRW	8' BOX	8' BOX DRW	6'4" BOX	6'4" RAMBOX	6'4" BOX DRW				
6.7L CUMMINS TURBO DIESEL I-6 / 656 6-SPEED	3.42	24,000	16,890	16,640	16,520	16,310	16,500	16,270	16,370	16,110	16,360	16,110	15,980	15,740	16,220	16,030	16,100	15,880	15,810	15,620
	3.73	26,000			18,520	18,310									17,980	17,740			17,810	17,620

DRW = DUAL REAR WHEEL. WEIGHTS GIVEN IN LB. NUMBERS IN BOLD REFLECT NEW MAX RATINGS.

MAXIMUM PAYLOAD CAPACITIES (WHEN PROPERLY EQUIPPED)

2500 AUTOMATIC TRANSMISSION													
	GVWR	REGULAR CAB		CREW CAB				MEGA CAB					
		8' BOX	4x4	6'4" BOX	6'4" RAMBOX	8' BOX	4x4	6'4" BOX	6'4" RAMBOX				
6.7L CUMMINS TURBO DIESEL I-6 / 68RFE 6-SPEED	9,000	2,520	2,050										
	10,000			3,120	2,650	2,950	2,500	2,920	2,470	2,740	2,270	2,570	2,120

2500 MANUAL TRANSMISSION													
	GVWR	REGULAR CAB		CREW CAB				MEGA CAB					
		8' BOX	4x4	6'4" BOX	6'4" RAMBOX	8' BOX	4x4	6'4" BOX	6'4" RAMBOX				
6.7L CUMMINS TURBO DIESEL I-6 / 656 6-SPEED	9,000	2,420	1,970										
	10,000			3,060	2,580	2,890	2,440	2,850	2,400	2,670	2,200	2,500	2,050

WEIGHTS GIVEN IN LB. NUMBERS IN BOLD REFLECT NEW MAX RATINGS.

3500 AUTOMATIC TRANSMISSION																		
	GVWR	REGULAR CAB				CREW CAB				MEGA CAB								
		8' BOX	8' BOX DRW	6'4" BOX	6'4" RAMBOX	8' BOX	8' BOX DRW	6'4" BOX	6'4" RAMBOX	6'4" BOX DRW	8' BOX	8' BOX DRW	6'4" BOX	6'4" RAMBOX	6'4" BOX DRW			
6.7L CUMMINS TURBO DIESEL I-6 / 68RFE 6-SPEED	11,100	4,210				4,210		4,080								4,040	3,920	
	11,500		4,360					4,080										
	11,600															4,040	3,920	
	11,700						4,190		4,030									
	12,000								4,580									
	12,300									4,630								
	12,400															4,650	4,500	
	14,000			6,700	6,530							6,190	5,960				6,030	5,840
	11,100	4,060																
	11,500	4,210			4,060		3,930											
6.7L CUMMINS HIGH OUTPUT TURBO DIESEL I-6 / AISIN 6-SPEED	11,600												3,890		3,760			
	11,700					4,030		3,870										
	12,000							4,420										
	12,300								4,470									
	12,400													4,490	4,350			
	14,000			6,580	6,370						6,040	5,800				5,880	5,680	

3500 MANUAL TRANSMISSION																	
	GVWR	REGULAR CAB				CREW CAB				MEGA CAB							
		8' BOX	8' BOX DRW	6'4" BOX	6'4" RAMBOX	8' BOX	8' BOX DRW	6'4" BOX	6'4" RAMBOX	6'4" BOX DRW	8' BOX	8' BOX DRW	6'4" BOX	6'4" RAMBOX	6'4" BOX DRW		
6.7L CUMMINS TURBO DIESEL I-6 / 656 6-SPEED	11,100	4,160															
	11,500		4,310			4,170		4,040									
	11,600													3,990	3,870		
	11,700					4,140		3,980									
	12,000								4,530								
	12,300									4,580							
	12,400													4,600	4,450		
	14,000			6,690	6,480						6,150	5,910				5,980	5,790

DRW = DUAL REAR WHEEL. WEIGHTS GIVEN IN LB. NUMBERS IN BOLD REFLECT NEW MAX RATINGS.

TURBO-PROVEN.

THE FORMIDABLE 6.7L CUMMINS® TURBO DIESEL. AVAILABLE AND SOLIDLY PROVEN IN OVER 2 MILLION RAM HEAVY DUTY APPLICATIONS.



You're pulling your boat with your new Ram 2500, or a massive trailer with your new Ram 3500. The superiority of impressive diesel torque from the long-proven available 6.7-liter Cummins Turbo Diesel keeps you in the comfort zone. The facts speak decisively: with over two million applications of a Cummins Turbo Diesel in a Ram truck, the history of this exceptional powertrain delivers capability and reliability second to none.

For 2013, Cummins improves the classic Turbo Diesel in Ram Heavy Duty models with a Next-Generation Diesel Exhaust Fluid (DEF)/Select Catalytic Reduction (SCR) system that's fully compliant with recent federal mandates. A new diesel cooling system dissipates heat 25 percent more efficiently — and now incorporates an improved, 11-blade fan. Superior capability comes in the form of the available Cummins High Output Turbo Diesel achieving a best-in-class^[1] 850 lb-ft of torque for Ram 3500 pickups.

When you're measuring capability, powertrain combinations count big. Credit our colleagues at AISIN® who designed the impressive new available AISIN AS69RC six-speed automatic to handle the available Cummins High Output ratings, higher vehicle weight ratings, and related axle ratios. The fully electronically controlled AISIN transmission makes the grade with tough internal components, a more aggressive Tow/Haul Mode, and a compact gear train. This is outstanding capability, reliability, and quality.

Improvements also apply to Ram's available class-exclusive^[3] G56 six-speed manual transmission, now modified to handle the increased torque of 660 lb-ft; its hard-finished gear system aims to reduce noise levels. The available 68RFE six-speed automatic transmission is mated to the 370 hp/800 lb-ft of torque Cummins version. Transfer cases boast robust strength. Established BorgWarner BW 44-46 and BW 44-47 cases — with electronic shift-on-the-fly or manually actuated capability, respectively — have long proven themselves, with long-life engineering, exceptional capability, and minimal noise, vibration, and harshness (NVH).

Think heavyweight champion — with paid scholarships to schools of engineering and economics. That's Cummins at work in Ram Heavy Duty, offering improved power and capability, decreased maintenance schedules, and state-of-the-art technology — like the new "smart" diesel exhaust brake — to help improve NVH and vehicle control.

+ **Class-exclusive^[3] six-speed manual — and more power than ever.** New calibrations from Cummins give you three engine outputs for enormous latitude. The 350 hp/660 lb-ft of torque version is mated to the standard G56 six-speed manual; available for Ram 2500 and 3500.

+ **Unsurpassed^[2] torque for Ram 2500.** The Cummins rated at 370 hp delivers an incredible 800 lb-ft of torque for Ram 2500. It's mated to the proven 68RFE six-speed automatic transmission, and is also available for Ram 3500 models.

+ **Best-in-class^[1] torque for Ram 3500.** Newly available for 2013 Ram 3500 is the Cummins High Output Turbo Diesel, paired only with the tough new AISIN six-speed automatic transmission. Best-in-class^[1] available torque is 850 lb-ft, backed with 385 horsepower; available for 3500 only.

+ **For ideal performance, all-new Ram Active Air technology** switches the air intake path, ensuring optimal power and torque under all grades, climates, and load/towing conditions. Exclusive to diesel-powered Rams.

+ **Bringing operating temperatures to ideal ranges** is a new diesel cooling system. The engineering encompasses a "low-slung" positioned charge air cooler, faster-sequenced water pumps, an efficient new 11-blade fan (instead of eight) and a unique, series-designed dual radiator system. Total heat reduction with the new design is significantly improved — some 25 percent over 2012 models.

+ **The new Cummins "smart" diesel exhaust brake** is standard on every Cummins. Think cruise-control efficiency; the brake offers greater towing control and improves load management, irrespective of the terrain.

+ **For optimum fuel filtration and water separation,** Cummins now utilizes a new top-access engine-mounted fuel filter and a second frame-mounted pre-filter to ensure enhanced contamination protection.

+ **Low cost of ownership and operation** is part of the Cummins process; oil change intervals with the Cummins are a time- and money-saving 15,000-mile interval under normal operating conditions.

+ **Biodiesel compatibility is built in.** All Cummins Turbo Diesels for Ram Heavy Duty pickups are B20-compatible.



All Cummins engines are backed by an unsurpassed^[3] 5-Year/100,000-Mile Powertrain Limited Warranty.^[5]



Ram 2500 Mega Cab® Laramie with available class-exclusive²¹ RamBox® Cargo Management System and available 6.7L Cummins™ Turbo Diesel shown in Black with Bright Silver Metallic lower. Properly secure all cargo.

5.7L HEMI® V8 ENGINE.

Some histories repeat themselves; others build on success. The hemispherical combustion chamber is a design that has proven itself to endure high-compression ratios with near-zero fatigue. For 2013, the distinguished HEMI V8 powerplant offers:

- + **Exceptional power and torque** for 2013 Ram 2500 and 3500 SRW models — 383 hp @ 5,600 rpm and 400 lb-ft of torque @ 4,000 rpm.
- + **Interactive Deceleration Fuel Shut-Off (iDFSO)**, to seamlessly turn off fuel flow during deceleration for increased fuel efficiency.
- + **A sophisticated electronic throttle control system**, to deliver exact amounts of fuel for premium performance and efficiency.
- + **Variable Valve Timing (VVT)**, to perfect engine breathing through precise valve control — and increase torque over a large rpm range.
- + **Dual spark plugs** — two for each cylinder — to help increase peak power and torque, increase fuel efficiency, burn ancillary exhaust emissions with greater efficiency, and smooth the idle.
- + **An ultra-high compression ratio of 10.5:1** along with dual knock sensors, for stellar performance and fuel efficiency.

The HEMI V8 backs you with one of the best warranties out there: our unsurpassed^[5] and fully transferable **5-Year/100,000-Mile Powertrain Limited Warranty.**^[5]

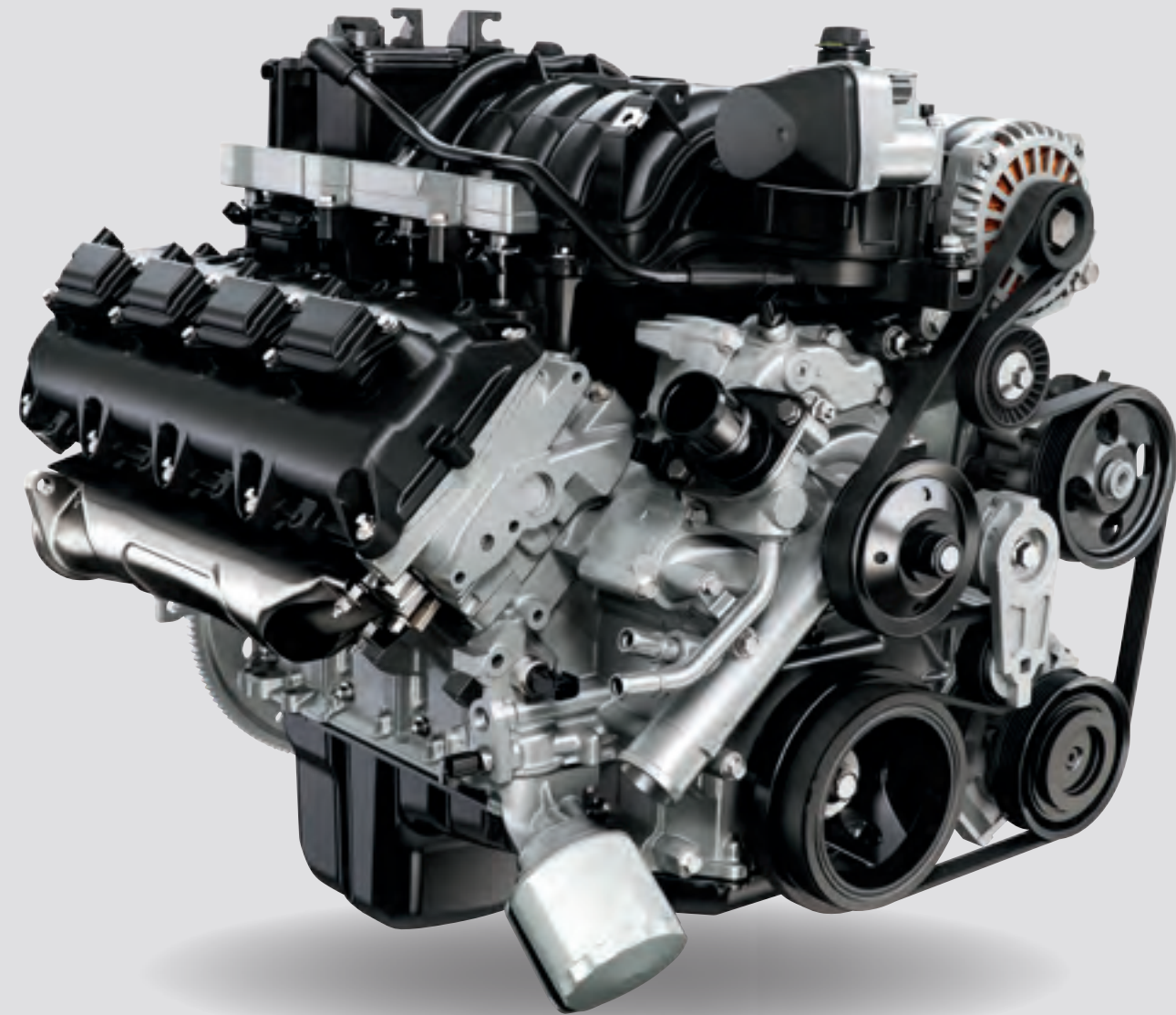

A LEGEND AT WORK.

THE 5.7-LITER HEMI® V8: IMPRESSIVE PERFORMANCE, HEAVY-DUTY CAPABILITY, AND EXCEPTIONAL DURABILITY.

The résumé of this world-famous engine includes propelling WWII Thunderbolt airplanes, helping define the distinctive Muscle Car Era, and vaulting new 2013 Ram Heavy Duty pickups to first-place consideration for the toughest jobs you face — whether hauling iron from the factory, or climbing that mountain with your camper.

The manifold advantages of the unstoppable hemispherical design of the 5.7-liter HEMI V8, along with VVT, are detailed at left. Now add robust transmissions and transfer cases to expand capability; all components utilize technologies and engineering protocols created specifically for heavy-duty use and long-term durability. And in this economy, improving performance and increasing fuel efficiency are bottom-line specific, for today, it's all about doing business better — and that includes HEMI V8 performance. With its hemispherical heads and VVT-engineering that improves engine breathing for increased response and torque — HEMI V8 performance makes it the natural standard powerplant for Ram 2500 and 3500 SRW models.

Powertrain partners to the HEMI V8 add strength. Mated to the Ram Heavy Duty 5.7-liter HEMI V8 is the sophisticated 66RFE six-speed automatic transmission, a component that exceeds typical demands for anticipated towing and hauling. The transmission offers driver-adaptive shifting, with three multiple clutch packs and a dual-stage hydraulic pump, all contributing to superb road manners and impressive hauling dynamics. The addition of dual filters on the dual-stage pump helps protect the pump and other components, with an independent lubrication cooler ensuring ample pressure under all conditions.

The transfer cases mated to the 5.7-liter HEMI V8 are the same as those utilized by the Cummins® Turbo Diesel — applications that prove unquestionable strength. The BorgWarner BW 44-46 transfer case features responsive electronic shift-on-the-fly engineering, with three operating ranges, plus Neutral. The manually actuated BW 44-47 case features three operating ranges, plus Neutral. Both units offer a low range reduction ratio of 2.64:1 — ideal for slow rock crawling or steep grades. When it comes to off-road capability or on-the-job performance, Ram Heavy Duty is designed to excel.



MAXIMUM PAYLOAD CAPACITIES (WHEN PROPERLY EQUIPPED)

		2500 AUTOMATIC TRANSMISSION											
		REGULAR CAB				CREW CAB				MEGA CAB®			
		8' BOX		6'4" BOX		6'4" RAMBOX®		8' BOX		6'4" BOX		6'4" RAMBOX	
5.7L HEMI V8 CNG / 66RFE 6-SPEED	GVWR	4x2	4x4	4x2	4x4	4x2	4x4	4x2	4x4	4x2	4x4	4x2	4x4
	8,800												1,620
5.7L HEMI V8 / 66RFE 6-SPEED	8,510				1,910		1,750						
	8,650	3,170	2,710										
	8,800			2,930	2,500	2,770	2,350	2,770	2,310	2,580	2,110	2,410	1,940
	WEIGHTS GIVEN IN LB. NUMBERS IN BOLD REFLECT NEW MAX RATINGS.												

		3500 AUTOMATIC TRANSMISSION											
		REGULAR CAB				CREW CAB				MEGA CAB			
		8' BOX		6'4" BOX		6'4" RAMBOX		8' BOX		6'4" BOX		6'4" RAMBOX	
5.7L HEMI V8 / 66RFE 6-SPEED	GVWR	4x2	4x4	4x2	4x4	4x2	4x4	4x2	4x4	4x2	4x4	4x2	4x4
	10,050				3,710		3,580						
	10,100	4,130											
	10,300		4,130										
	10,700				4,240		4,090						
	11,000							4,500		4,430		4,300	
11,300								4,640		4,550		4,410	
WEIGHTS GIVEN IN LB. NUMBERS IN BOLD REFLECT NEW MAX RATINGS.													

MAXIMUM LOADED TRAILER WEIGHTS (WHEN PROPERLY EQUIPPED)

		2500 AUTOMATIC TRANSMISSION													
		REGULAR CAB				CREW CAB				MEGA CAB®					
		8' BOX		6'4" BOX		6'4" RAMBOX®		8' BOX		6'4" BOX		6'4" RAMBOX			
5.7L HEMI V8 CNG / 66RFE 6-SPEED	AXLE RATIO	GCWR	4x2	4x4	4x2	4x4	4x2	4x4	4x2	4x4	4x2	4x4	4x2	4x4	
	3.73	15,000									7,650				
	4.10	20,000	14,350	13,890	13,960	13,530	13,800	13,380	13,800	13,340	13,610	13,140	13,440	12,970	
5.7L HEMI V8 / 66RFE 6-SPEED	3.73	18,000	12,350	11,890	11,960	11,530	11,800	11,380	11,800	11,340	11,610	11,140	11,440	10,970	
	4.56	18,000									11,230		11,070		
WEIGHTS GIVEN IN LB. NUMBERS IN BOLD REFLECT NEW MAX RATINGS.															

		3500 AUTOMATIC TRANSMISSION													
		REGULAR CAB				CREW CAB				MEGA CAB					
		8' BOX		6'4" BOX		6'4" RAMBOX		8' BOX		6'4" BOX		6'4" RAMBOX			
5.7L HEMI V8 CNG / 66RFE 6-SPEED	AXLE RATIO	GCWR	4x2	4x4	4x2	4x4	4x2	4x4	4x2	4x4	4x2	4x4	4x2	4x4	
	3.73	18,000	11,860	11,660	11,490	11,370	11,360	11,220	11,330	11,170	11,260	11,080	11,130	10,940	
	4.10	20,000	13,860	13,660	13,490	13,370	13,360	13,220	13,330	13,170	13,260	13,080	13,130	12,940	
WEIGHTS GIVEN IN LB. NUMBERS IN BOLD REFLECT NEW MAX RATINGS.															

6,730-lb MAXIMUM PAYLOAD*



NEW MAX CAPABILITY GETS THE JOB DONE.

Ram Heavy Duty pickups dominated in the task-specific ratings that defined *job-rated capability*. Now they have the boldness to advance that concept into 21st-century thinking. New maximum ratings boost long-established strengths to new levels, delivering bigger payloads and tougher towing numbers.

The newly increased GVWRs (Gross Vehicle Weight Ratings) are helped by the indomitable Cummins® powerplants. New 2013 Ram 2500 with the available 6.7L Cummins Turbo Diesel vaults maximum GVWR up to 10,000 lb* — serious muscle to meet recreational needs and commercial assignments. On new Ram 3500 dually, the new maximum GVWR jumps to 14,000 lb* — a heavy-duty ideal for all push/pull/haul/do requirements.

It gets better. On new Ram 3500 Heavy Duty, a higher front axle weight rating joins a beefed-up frame, with steel now rated at 50 ksi. Maximum capability in front is ideal for snowplows or hydraulic front-mounted machinery. When it comes to meeting the need, the new max capability figures show that we're ready for it all. New Ram Heavy Duty 2500 and 3500 pickups.

*When properly equipped. Properly secure all cargo.



REST EASY. RAM DOES ALL THE WORK.

NEW RAM BENCHMARKS PERFORMANCE, OFFERING THE FIRST-EVER HEAVY DUTY DUALY WITH STANDARD ELECTRONIC STABILITY CONTROL (ESC).^[4]

Check out the details below, and it's obvious that Ram ripples with the biceps and backbone to conquer heavy-duty demands with ease. What's less obvious to the eye are the brains — technology to make these workhorses work better. For 2013, towing, hauling, maneuvering, and handling are all impacted by the new ESC^[4] system — now standard on all 2013 Ram Heavy Duty 2500/3500 models. The 2013 Ram 3500 dually achieves a new benchmark, with a class-exclusive^[1] application of the comprehensive ESC^[4] system in a DRW configuration.

Designed to master maneuverability and control, ESC^[4] is calibrated to each model's horsepower and torque. The system contains (but isn't limited to) the four-channel **Antilock Brake System (ABS)**, **Electronic Brake Force Distribution**, **Rain Brake Support**, **Brake Assist**, **Ready Alert Braking (RAB)**, **Hydraulic Boost Compensation**, **Trailer Sway Control**,^[4] **Hill Start Assist**, and a full-function, controllable, and on-demand **All-Speed Traction Control System**. Searching for a heavy-duty pickup with control technology far beyond the competition? New Ram Heavy Duty is the working solution.

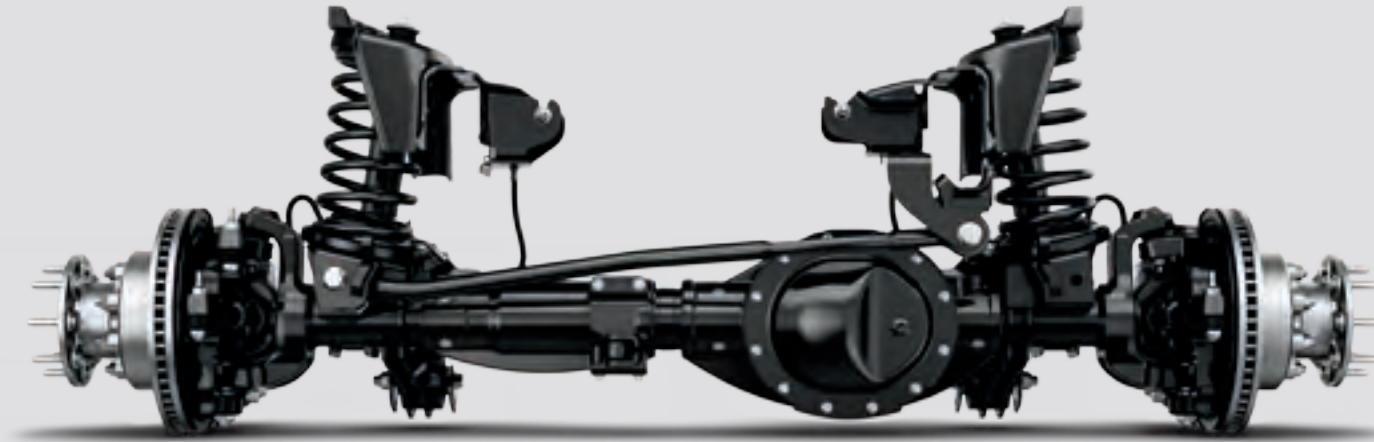

CAPABLE EFFICIENCY PUTS RAM IN FRONT. Extensive front axle developments in new Ram 3500 4x4 pickups start with a new front axle disconnect for increased efficiency. Front axles have also been enhanced for greater capability with new maximum front GAWRs; they're increased by 500 lb, raising maximum FGAWR to 6,000 lb.* Further advantages include engineering that reduces parasitic losses and new lower viscosity lube that reduces resistance, both helping to enhance fuel efficiency.

+ A NEW FULLY-INTEGRATED REAR FRAME STRUCTURAL CROSSMEMBER WITH PROVISIONS FOR A FIFTH-WHEEL OR GOOSENECK HITCH HELPS RAMP UP TOWING CAPABILITY* FOR NEW 2013 RAM 3500 MODELS. THESE ARE TRUCKS WITH BACKBONE, DESIGNED AND BUILT FOR THE TOUGHEST TOWING.

+ MODIFIED REAR AXLES HELP ACHIEVE NEW MAXIMUM CAPABILITY. ON RAM 3500 HEAVY DUTY MODELS, THE RECONFIGURED HOTCHKISS (LEAF) SUSPENSION LETS YOU LOAD RAM TO GROANING PAYLOADS — WITH NO COMPROMISES IN HANDLING OR ROLL DYNAMICS.

+ THE NEW CUMMINS® HIGH OUTPUT TURBO DIESEL MATED TO THE NEW AISIN® SIX-SPEED AUTOMATIC PROVIDES AN AVAILABLE POWERTRAIN DESIGNED FOR THE RIGORS OF COMMERCIAL-GRADE ASSIGNMENTS. THIS LEVEL OF POWER WARRANTS A BOOST IN BACK. PUT IT INTO A NEW RAM 3500 DUALY, ADD THAT NEW, **LARGER 11.8-INCH REAR RING GEAR**, AND YOU'VE GOT CLASS-LEADING^[1] MAX GCWRs* AND OUTSTANDING TOWING FIGURES.*

+ NEW 18- AND 20-INCH' WHEELS. AVAILABLE FOR RAM 3500 SINGLE-REAR-WHEEL MODELS, THEY ADD AUTHORITY TO THE NEW SCULPTED, FLOWING AERODYNAMIC EXTERIOR TOUCHES.

*When properly equipped.
†Late availability.

+ A NEW PREMIUM RECIPROCATING BALL STEERING GEAR WITH REDESIGNED STEERING KNUCKLES AND BALL JOINTS AND A MORE ROBUST STEERING LINKAGE ON RAM 3500 MODELS ENHANCE STEERING AND CONTROL WITH A MORE PRECISE ON-CENTER FEEL — AND THEY DIRECTLY CONTRIBUTE TO RAM'S IMPRESSIVE HIGHER GVWRs AND PAYLOAD/TOWING FIGURES.*

+ UPDATED ENGINE, TRANSMISSION, AND BODY MOUNTS, INCLUDING PIONEERING "HYDRO-MOUNTS" AT THE C-PILLAR, GIVE NEW RAM 3500 HEAVY DUTY PICKUPS OUTSTANDING CONTROL OVER NOISE, VIBRATION, AND HARSHNESS (NVH) — DESPITE THE TRUCK'S ENGINEERED-IN APPETITE FOR HEAVIER PAYLOADS.

+ A NEW THREE-LINK FRONT SUSPENSION ON 2013 RAM 3500 HEAVY DUTY PICKUPS ENSURES APPROPRIATE ROLL STIFFNESS THAT MATCHES THE VEHICLE'S NEW HIGHER GVWRs — WITH NO SACRIFICE OF RIDE, HANDLING, AND MANEUVERABILITY, IRRESPECTIVE OF CARGO OR PAYLOAD.

+ A MORE REFINED AND PRECISE FRONT AXLE GEAR SET ON NEW RAM 3500 4x4 APPLICATIONS IMPROVE AXLE PERFORMANCE AND HELP BOOST FUEL EFFICIENCY. THESE IMPROVEMENTS COME FROM SUPERFINE PRECISION CUTS IN THE GEARS, WITH ADVANTAGES THAT INCLUDE REDUCED GEAR WHINE, LESS PERCEIVED HARSHNESS, LESS GEAR PLAY, AND TIGHTER CONTACT, ESPECIALLY DURING ACCELERATION.

+ A NEW FRONT AXLE LUBRICANT ON RAM 4x4 MODELS ALSO PLAYS A ROLE, PROVIDING ULTRA-LOW RESISTANCE — AN ENABLER THAT HELPS ENHANCE FUEL EFFICIENCY.

+ THE REVISED LADDER FRAME WITH EIGHT TOUGH CROSSMEMBERS AND WIDER RAILS ON NEW RAM 3500 LETS YOU TACKLE THE MOST CHALLENGING PAYLOADS WITH ASSURED CAPABILITY AND UNQUESTIONED STRENGTH.

+ FRAME STRENGTH MEASURES UP — AT AN INCREDIBLE 50 KSI. THE HIGH-STRENGTH STEEL ON RAM 3500 MODELS CARRIES THE SAME STANDARD USED TO BUILD BRIDGES AND SUBMARINE HULLS. THIS IS FRAME STRENGTH BUILT TO WORK.

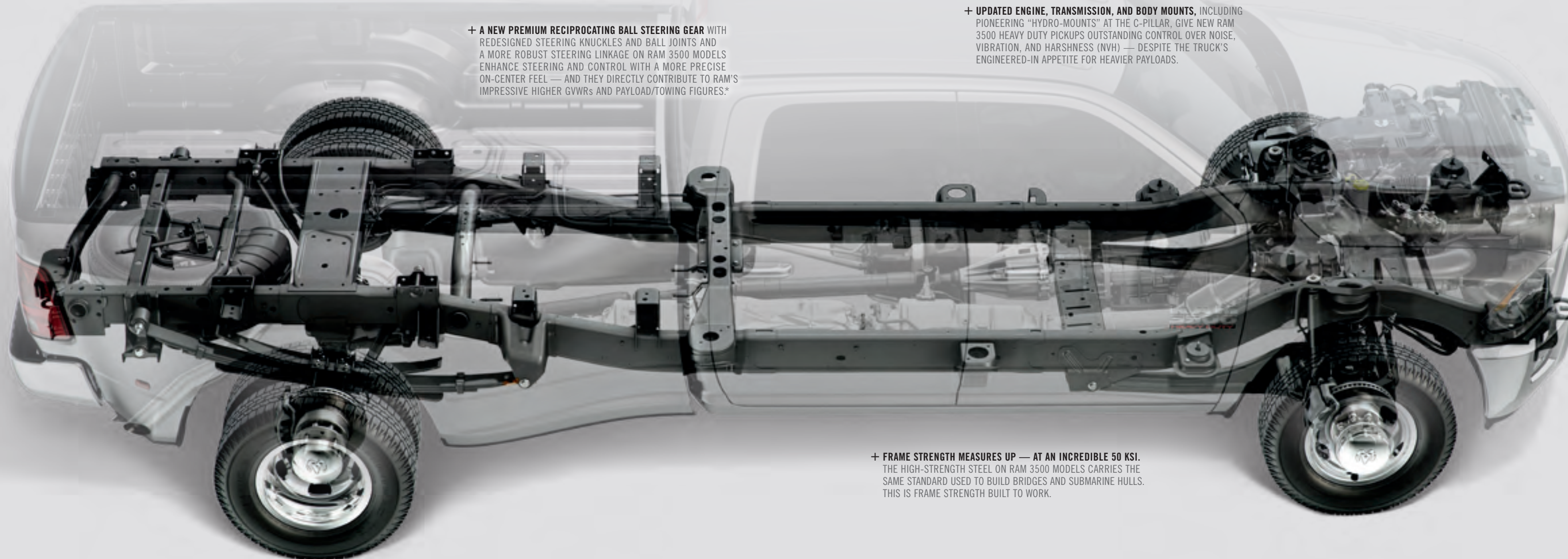

RAM HEAVY DUTY. TOTALLY ENGINEERED TO FLOW WITH THE TOW.

Now, backing up to that hitch in your 2013 Ram Heavy Duty moves you forward at the speed of ingenuity. Count on state-of-the-art innovations that let you master towing in all terrains and conditions, because this is all about straight-from-the-factory towing capability. Assets abound, starting with class-leading^[1] available torque from the Cummins® High Output on Ram 3500. All Cummins engines feature the new “smart” diesel exhaust brake — indispensable on up- and downhill grades — and new Ram Active Air, offering outstanding air intake for superb performance. All Ram models come with the new, standard Electronic Stability Control (ESC)^[4] system, comprehensive technology that augments the invaluable standard Tow/Haul Mode.

Towing is really about unparalleled strength. Significant frame and component enhancements culminate in an all-new, fully-integrated rear frame structural crossmember for 2013 Ram 3500, along with a new factory-installed trailer tow connector; it's conveniently located in the bed, and comes with the available Fifth-Wheel/Gooseneck Tow Prep Package — engineering to improve the heaviest trailering requirements. Inside, the available rear-mounted camera^[6] displays all-new Active Grid Lines on the available new 8.4-inch full-color touch screen on select models, vastly simplifying trailer/hitch alignment for easy one-person operation. No matter what's behind you, this is the truck you want in front. The new 2013 Ram Heavy Duty.



New 2013 Ram 3500 Regular Cab Tradesman dually with Chrome Appearance Group and available Cummins High Output Turbo Diesel shown in Bright White, applying new maximum towing to a gooseneck trailer. Properly secure all cargo.



The new, large available 8.4-inch touch-screen radio in select new 2013 Ram Heavy Duty models now offers full-color displays, including three-dimensional imaging of landmarks and city modeling. New Active Grid Lines in the display are another Ram advantage — they're invaluable when backing up, changing with each steering wheel movement. Now you can easily and accurately align your hitch to the trailer, with no need to hop out to double-check, or bother with a spotter.

All-new for 2013: the Integrated Switch Bank. Conveniently mounted in the dashboard, it offers fingertip management of the standard ESC^[4] system, the available Trailer Brake Controller (if equipped), and the Tow/Haul Mode, with controls for other available features — such as heated/ventilated seats, heated steering wheel, etc.



NEAR RIGHT: AVAILABLE NEW FIFTH-WHEEL/GOOSENECK TOW PREP PACKAGE INCLUDES FACTORY-INSTALLED TRAILER TOW CONNECTING TECHNOLOGY, WITH THE 7-PIN IN-BED CONNECTOR NOW PACKAGED WITH THE SYSTEM FOR INSTANT ACCESS AND SIMPLE OPERATION.

CENTER: RAM HEAVY DUTY 3500 PICKUPS OFFER CRITICAL FRAME IMPROVEMENTS FOR FIFTH-WHEEL TOWING NEEDS; COUNT ON 50 KSI STEEL THROUGHOUT; NEW WIDER FRAME RAILS; AND INCREASED STRENGTH FROM TWO MORE CROSSMEMBERS, INCLUDING A NEW REAR FRAME STRUCTURAL CROSSMEMBER. SHOWN: FIFTH-WHEEL HITCH WITH GLIDER, AN AUTHENTIC ACCESSORY BY MOPAR.

FAR RIGHT: THE MANY MODIFICATIONS TO THE FRAME OF THE NEW 3500 PICKUP, DETAILED EARLIER, SMARTLY ADDRESS GOOSENECK HAULING. NATURALLY, THE BALL EASILY REMOVES WHEN YOU NEED THE ENTIRE FLAT FLOOR OF YOUR CARGO BED. SHOWN WITH GOOSENECK BALL, AN AUTHENTIC ACCESSORY BY MOPAR.



NEW RAM: ACHIEVEMENT MEASURED BY BRILLIANCE.

+ **TRIPLE-SEALED DOORS WITH WEATHER STRIPPING.** IT'S ALL ABOUT ISOLATING THE INTERIOR OF NEW RAM, AND IT WORKS. THE PROCESS KEEPS MOISTURE AND DUST OUT, AND ALLOWS MINIMAL INTRUSION OF NOISE, VIBRATION, AND HARSHNESS (NVH).

+ **WIPER BLADES HAVE BEEN REPOSITIONED.** THE DESIGN TUCKS THE BLADES BENEATH THE HOOD COWL, REDUCING GLARE, EXTENDING AERODYNAMIC EFFICIENCY, AND AUGMENTING THE CLEAN, STREAMLINED APPEARANCE OF NEW 2013 RAM HEAVY DUTY.



+ **KEY FOBBS ARE MORE ADVANCED THAN EVER. THE NEW, AVAILABLE ALL-SECURE™ LOCKING SYSTEM** CONTROLS THE DOORS, THE TAILGATE, AND, IF EQUIPPED, BOTH AVAILABLE RAMBOX® SYSTEM BINS. THE FOBBS ALSO CONTROL THE AVAILABLE PASSIVE ENTRY/KEYLESS ENTER 'N GO. APPROACH YOUR RAM WITH FOB, ENTER, AND MOVE. IT'S SIMPLER THAN EVER.

+ **NEW HEADLAMPS ON SELECT RAM HEAVY DUTY** MODELS ARE MODEL-SPECIFIC. QUAD LENS HALOGEN LAMPS ARE STANDARD. ON HIGH-END RAM MODELS, ALL-NEW AVAILABLE PROJECTOR-BEAM BIFUNCTIONAL HEADLAMPS OFFER OUTSTANDING LUMINOSITY, AND ARE AUGMENTED BY SUPPLEMENTAL LED LAMPS.



+ **HUGE 7 x 11-INCH TRAILER TOW MIRRORS OFFER MULTIPLE-PERSPECTIVE REAR VIEWS,** WITH A SCULPTED AERODYNAMIC DESIGN THAT HELPS IMPROVE FUEL EFFICIENCY.



DUAL FUNCTIONALITY IS BY DESIGN: WHEN VERTICAL, THEY'RE IDEAL FOR TOWING. FOR EVERYDAY DRIVING CONVENIENCE, FLIP THEM OVER TO HORIZONTAL. (STANDARD, 3500; AVAILABLE, 2500)

+ **AN AVAILABLE NEW REAR CENTER HIGH-MOUNTED STOP LAMP (CHMSL) CAMERA^{®1}** FOR THE 2013 RAM HEAVY DUTY PORTFOLIO ENSURES INVALUABLE VIEWS OF THE CARGO BED. IT'S IDEAL FOR A LAST-MINUTE CHECK OF YOUR PAYLOAD, OR WHEN HOOKING UP A BED-MOUNTED GOOSENECK OR FIFTH-WHEEL TRAILER HITCH.



+ **THE AVAILABLE CLASS-EXCLUSIVE^{®1} RAMBOX® CARGO MANAGEMENT SYSTEM** PROVES AS POPULAR AS EVER. NEW RAM 2500/3500 CREW CAB AND MEGA CAB® MODELS ADD CAPABILITY TO THEIR 6-FOOT 4-INCH BEDS. THE SYSTEM COMPRISES TWO HUGE, DRAINABLE AND ILLUMINATED SIDE BINS — AND THEY'RE NOW LOCKABLE WITH THE NEW ALL-SECURE™ LOCKING SYSTEM. INCLUDED WITH THE RAMBOX SYSTEM IS A CARGO BED EXTENDER/DIVIDER (STORED NEATLY IN FRONT OF THE BED WHEN NOT IN USE), CARGO RAILS, AND FOUR ADJUSTABLE CLEATS.

+ **LOOK FOR MULTIFUNCTIONAL TECHNOLOGY EVERYWHERE — EVEN THE TAILGATE HANDLE.** IT HOUSES AN AVAILABLE BACK-UP CAMERA^{®1} WITH NEW HIGHER DEFINITION AND ALL-NEW DYNAMIC GRID LINE IMAGING. IT ALL APPEARS IN THE NEW AVAILABLE FULL-COLOR CENTER-STACK DISPLAY.



+ **THE SLEEK NEW EXTERIOR STYLING OFFERS NUMEROUS IMPROVEMENTS,** INCLUDING NEW UNIQUE GRILLE TEXTURES, NEW ONE-PIECE OUTER PANELS, AND A SUPER-TOUGH HYDROFORMED INNER STRUCTURE FOR THE ENGINE COMPARTMENT.

+ **NEW, IMPROVED AVAILABLE SIDE STEPS HAVE BEEN LENGTHENED.** A WHEEL-TO-WHEEL DESIGN EASES ACCESS TO THE CARGO BED AND IMPROVES AIR FLOW. THE REDUCTION OF WIND RESISTANCE IMPROVES AERODYNAMICS AND HELPS ACHIEVE MORE FUEL-EFFICIENT PERFORMANCE.



+ **EVEN THE NEW AVAILABLE LED TAILLAMPS ARE MORE EFFICIENT,** USING LESS ENERGY THAN THE TYPICAL INCANDESCENT BULB — AN EDGE CONTRIBUTING TO FUEL EFFICIENCY. THE LED TAILLAMP ELEMENTS ARE NOW INDIRECTLY LIT, FOR IMPROVED VISIBILITY IN TWILIGHT HOURS.

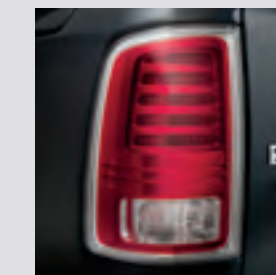

RIPPED MUSCLE, FLAWLESS SKIN.

A completely new approach to this design gives you exactly what a work truck should be: exceptional power, the capability to pull off heavy-duty assignments with confidence, and head-turning good looks.

Here, new exterior styling comes to work with impressive aerodynamic efficiency — and an on-road stance that boasts a muscular, athletic profile. In front, new grille treatments now offer model-specific identities, with an overall greater use of chrome and defining highlights. Quad lens headlamps are now standard, with all-new projector-beam headlamps available on upscale Ram Heavy Duty models, offering a sharp new look and vastly improved forward and peripheral lighting. New, intelligently designed touches in the side lenses give you a subtle Ram's Head logo for those in the know.

From the revised side badging that distinguishes models and powertrains to the available new wheels, new 2013 Ram Heavy Duty 2500/3500 pickups visually convey no-nonsense capability with unmistakable Ram style. Add it all up: new exterior design elements. Five new exterior colors. Sharp two-tone paint treatments for select models. Everywhere you look, this is Ram Heavy Duty like never before.



Properly secure all cargo.



New 2013 Ram 2500 Crew Cab Tradesman with available class-exclusive RamBox® Cargo Management System and available 6.7L Cummins® Turbo Diesel shown in Bright White. Properly secure all cargo.

Properly secure all cargo.



2013 Ram Power Wagon® gives you phenomenal off-road capability. Shown here: 2013 Ram 2500 Power Wagon in Deep Cherry Red Crystal Pearl with Black lower with available class-exclusiveSM RamBox® Cargo Management System.



2013 Ram 3500 Crew Cab Laramie Longhorn DRW shown in Western Brown Pearl with White Gold Metallic lower. Properly secure all cargo.



THIS ARCHITECTURE REACHES NEW HEIGHTS.

These interiors are unparalleled in our history. The all-new Ram PowerNet electrical architecture provides a high-speed network to connect all systems. New Sapphire Blue ambient lighting in select models joins Sapphire Blue backlighting in all models. Step inside new Ram Heavy Duty, and step up to technology and comfort that rise to the top.



NEW INSTRUMENTATION RUNS RINGS AROUND CONVENTION. Select trim levels offer high-end electronics with a degree of sophistication never seen in Ram trucks. Assets include an available all-new six-ring instrument cluster with a 7-inch, full-color Multi-View Display with dozens of visual cues (telltales) for real-time information on truck functions, communications, and the radio. It's all operated through steering wheel-mounted cursors for instant menu access.

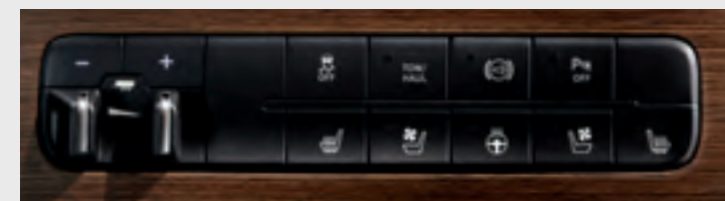

ALL-NEW SWITCH BANK OFFERS SUPREME CONTROL. All Ram models let you control the new standard Electronic Stability Control (ESC)⁽⁴⁾ or the available heated and ventilated seats and heated steering wheel with a new instrument panel-mounted Integrated Switch Bank that puts full functionality at your fingertips.

New for Ram Heavy Duty is an available Upfitter Interface Module, now enhanced with 53 inputs/outputs — one of the most upfitter-friendly designs for any pickup, and a first for Ram Heavy Duty.

LEFT: RAM LARAMIE LONGHORN INTERIOR SHOWN IN CATTLE TAN/BLACK.
TOP RIGHT: RAM LARAMIE LONGHORN INTERIOR SHOWN IN CANYON BROWN/LIGHT BEIGE.
LOWER RIGHT: RAM MEGA CAB® LARAMIE INTERIOR SHOWN IN BLACK.



The 2013 Ram Mega Cab offers the most interior volume of any full-size heavy-duty pickup.⁽⁵⁾



DYNAMIC NEW FULL-COLOR INSTRUMENTATION. THIS IS HOW MAN MERGES WITH HIS MACHINE.



THE UCONNECT® WORLD: STAY IN CONSTANT TOUCH. AND DO IT HANDS-FREE.



A NOD TO THE PAST — AND TO THE TECHNOLOGY OF THE FUTURE. For the 2013 Ram 2500/3500, each trim level now reflects a bold new look for the instrument panel and EVIC (Electronic Vehicle Information Center) display. For towing, hauling, and vehicle operation data, this is a full-function information center with an interface that leaves no doubt who's in control. It's pure Ram, all the way.

THE NEXT LEVEL OF EVIC. This is so not your uncle's truck. Vibrant, full-color graphics from the available new 7-inch Multi-View Display use stunning Thin Film Transistor (TFT) technology. Scroll through roller-type interfaces with instant vehicle information, including graphics for 34 menu options. The level of information is astonishing.

ALL-NEW POWERNET ELECTRICAL ARCHITECTURE. It's the equivalent of a high-speed Internet connection in your Ram, conveying information about virtually every facet of vehicle operation through multiple "smart" modules located throughout the vehicle.

THE UPSHOT: KNOWLEDGE. Leave the intuitive, state-of-the-art technology aside for a moment. In the final analysis, you've got a wealth of info right at your fingertips, with steering wheel-mounted cursors that take you through dozens of different pieces of real-time information — everything from trailer data to critical pressures and powertrain operating temperatures. This is technology driving to be the best.



UCONNECT 3.0. With four-line full LCD display; AM/FM with remote USB; iPod® integration. Available: SiriusXM Satellite Radio,^[7] remote CD player.

UCONNECT 5.0. With 5-inch full-color touch-screen display; AM/FM with remote USB; iPod integration; Bluetooth® connectivity for hands-free phone, streaming audio, Voice Command,^[8] text message reader; rearview camera^[6]-ready; SiriusXM Satellite Radio.^[7] Available: remote CD player.

SIRIUSXM PREMIER: OVER 160 CHANNELS.

Enjoy every available satellite radio channel: commercial-free music, sports, news, talk, and entertainment, including Howard Stern, every NFL® MLB® and NHL® game, every NASCAR® race, and more. Includes SiriusXM Latino — more than 20 channels dedicated to Spanish language programming.

UCONNECT 8.4A. With 8.4-inch full-color touch-screen display; AM/FM with remote USB/SD; iPod integration; Bluetooth connectivity for hands-free phone, streaming audio, Voice Command,^[8] text message reader; also includes customer- or dealer-activated navigation; HVAC control integration; smartphone connectivity; available 3G WiFi Hotspot;^[9] rearview camera^[6]-ready; SiriusXM Satellite Radio.^[7] Available: remote CD player.

UCONNECT 8.4AN. All features of all previous descriptions, plus premium navigation with one-step voice destination entry; 3-D city modeling and landmarks; digital terrain modeling; 911/assist calling; HD radio; SiriusXM Satellite Radio;^[7] SiriusXM Travel Link;^[7] SiriusXM Traffic.^[7] Available: remote CD player.



AUTHENTIC RAM ACCESSORIES

WITH YOU EVERY MILE. Mopar® is with you the moment you get your new keys and for every mile thereafter. Mopar helps you maintain and make your ride your own with parts and accessories of every kind — all original equipment designed by the same engineers of your vehicle — specifically for your model. There's no guesswork, just get-it-right-the-first-time satisfaction with seamless fit and function, exact color matches, and high-quality materials that have been thoroughly tested for the long haul.

Mopar also assures you with expert technicians who know your make and model best, Mopar Vehicle Protection™ plans, Express Lane Service, and with our online Mopar Owner Connect™ Web site (register at owners.ramtrucks.com). In short, Mopar support is ongoing — to keep your Ram truck at its best. Mopar, with you every mile. For more information, visit us at mopar.com

Properly secure all cargo.

Above: Ram 2500 Crew Cab Tradesman in Bright White shown with Wheel Flares, Stainless Steel Tubular Side Steps, RamBox® Cargo Organizer, Sliding Toolbox, and Bed Step.



Commercial-Grade Toolbox



Fifth-Wheel Hitch with Glider



Aluminum Ladder Rack





TRADESMAN

2500

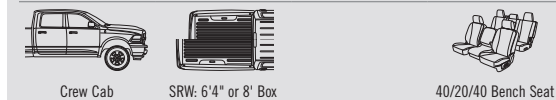

3500

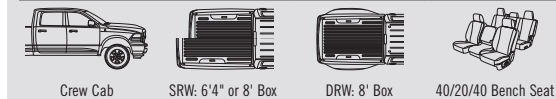
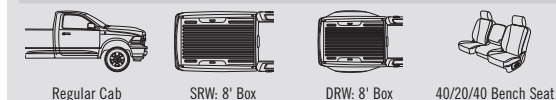

STANDARD FEATURES MECHANICAL

2500: 5.7L HEMI® V8 with heavy-duty cooling and 66RFE 6-speed automatic transmission

3500 SRW: 5.7L HEMI V8 with heavy-duty cooling and 66RFE 6-speed automatic transmission • 7 x 11-inch trailer tow mirrors • Tow hooks

3500 DRW: 6.7L Cummins® Turbo Diesel with heavy-duty cooling and 6-speed manual transmission • 7 x 11-inch trailer tow mirrors • Tow hooks

2500/3500: Electronic Stability Control (ESC)⁽⁴⁾ system, which includes 4-wheel ABS, Brake Assist, Rain Brake Support, Ready Alert Braking, All-Speed Traction Control, Electronic Roll Mitigation, Hill Start Assist, and Trailer Sway Control⁽⁴⁾ • Manual part-time transfer case (on 4x4 models) • 6-foot 4-inch box models: 31-gallon fuel tank • 8-foot box models: 32-gallon fuel tank

INTERIOR

Vinyl 40/20/40 front bench seat • Vinyl folding rear bench on Crew Cab models • Vinyl floor covering • Multistage front air bags⁽¹⁰⁾ • Supplemental side-curtain air bags⁽¹⁰⁾ • Supplemental front-seat side-mounted air bags⁽¹⁰⁾ • Tilt steering wheel • Automatic headlamp control • Air conditioning • Power windows and door locks (on Crew Cab models) • Uconnect® 3.0 AM/FM radio • Media hub with MP3 auxiliary jack and 1.5-amp USB port • 3.5-inch Electronic Vehicle Information Center (EVIC) located in instrument panel cluster

EXTERIOR

Black front and rear bumpers • Black grille surround and inserts • Black fold-in sideview mirrors • Quad lens halogen headlamps • Bed rail caps • Locking tailgate (Regular Cab) • Power locking tailgate (Crew Cab) • 4- and 7-pin trailer wiring harness/connectors • Class V trailer hitch receiver • 17-inch steel wheels (2500/3500 DRW) • 18-inch steel wheels (3500 SRW)



POWER WAGON® TRADESMAN

2500



STANDARD FEATURES MECHANICAL

2500 Crew Cab 4x4 only: 5.7L HEMI V8 with heavy-duty cooling and 66RFE 6-speed automatic transmission • 180-amp alternator • Tow hooks • Skid plates for the fuel tank and transfer case • Electronic disconnecting front stabilizer (or sway) bar • Front and rear electronic locking differentials • 4.56:1 axle ratio • 12,000-lb WARN® winch • ESC⁽⁴⁾ system • Manual part-time transfer case • 31-gallon fuel tank

INTERIOR

Vinyl 40/20/40 front bench seat • Vinyl folding rear bench • Vinyl floor covering • Multistage front air bags⁽¹⁰⁾ • Supplemental side-curtain air bags⁽¹⁰⁾ • Supplemental front-seat side-mounted air bags⁽¹⁰⁾ • Tilt steering wheel • Automatic headlamp control • Air conditioning • Power windows and door locks • Uconnect 3.0 AM/FM radio • Media hub with MP3 auxiliary jack and 1.5-amp USB port • 3.5-inch EVIC located in instrument panel cluster

EXTERIOR

Chrome front and rear bumpers • Fog lamps • Black grille surround and inserts • Black headlamp filler panel • Black wheel flares • Black fold-in sideview mirrors • Quad lens halogen headlamps • Bed rail caps • Power locking tailgate • Power Wagon tailgate decal • 4- and 7-pin trailer wiring harness/connectors • Class V trailer hitch receiver • 17-inch forged aluminum wheels with 33-inch LT All-Terrain tires



SLT

2500

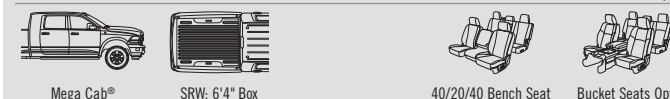
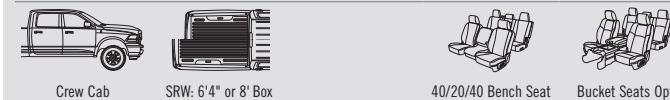
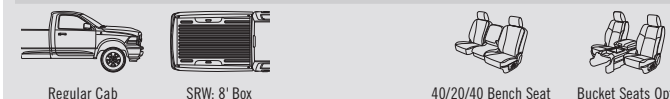

3500



STANDARD FEATURES MECHANICAL

2500: 5.7L HEMI V8 with heavy-duty cooling and 66RFE 6-speed automatic transmission

3500 SRW: 5.7L HEMI V8 with heavy-duty cooling and 66RFE 6-speed automatic transmission • 7 x 11-inch trailer tow mirrors • Tow hooks

3500 DRW: 6.7L Cummins Turbo Diesel with heavy-duty cooling and 6-speed manual transmission • 7 x 11-inch trailer tow mirrors • Tow hooks

2500/3500: ESC⁽⁴⁾ system • Electronic part-time transfer case (on 4x4 models) • Electronic trailer brake controller • Remote keyless entry • 6-foot 4-inch box models: 31-gallon fuel tank • 8-foot box models: 32-gallon fuel tank

INTERIOR

Cloth 40/20/40 front bench seat • Cloth folding rear bench on Crew Cab and Mega Cab models • Carpet floor covering • Multistage front air bags⁽¹⁰⁾ • Supplemental side-curtain air bags⁽¹⁰⁾ • Supplemental front-seat side-mounted air bags⁽¹⁰⁾ • Tilt steering wheel • Automatic headlamp control • Air conditioning • Power windows and door locks • Uconnect 3.0 AM/FM/SAT radio • Media hub with MP3 auxiliary jack and 1.5-amp USB port • 3.5-inch EVIC located in instrument panel cluster • Overhead console • Power sliding rear window on Crew Cab and Mega Cab models

EXTERIOR

Chrome front and rear bumpers • Chrome grille surround with Black inserts • Quad lens halogen headlamps • Chrome door handles • Black, power heated fold-in sideview mirrors • Bed rail caps • Power locking tailgate • 4- and 7-pin trailer wiring harness/connectors • Class V trailer hitch receiver • 17-inch chrome steel wheels (2500/3500 DRW) • 18-inch chrome steel wheels (3500 SRW)



BIG HORN/LONE STAR

2500

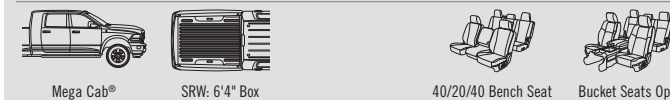
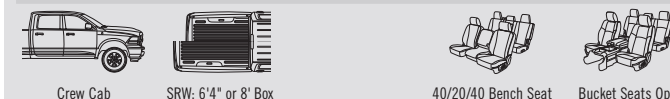

3500



STANDARD FEATURES MECHANICAL

2500: 5.7L HEMI® V8 with heavy-duty cooling and 66RFE 6-speed automatic transmission

3500 SRW: 5.7L HEMI V8 with heavy-duty cooling and 66RFE 6-speed automatic transmission • 7 x 11-inch trailer tow mirrors • Tow hooks

3500 DRW: 6.7L Cummins® Turbo Diesel with heavy-duty cooling and 6-speed manual transmission • 7 x 11-inch trailer tow mirrors • Tow hooks

2500/3500: Electronic Stability Control (ESC)⁽⁴⁾ system, which includes 4-wheel ABS, Brake Assist, Rain Brake Support, Ready Alert Braking, All-Speed Traction Control, Electronic Roll Mitigation, Hill Start Assist, and Trailer Sway Control⁽⁴⁾ • Electronic part-time transfer case (on 4x4 models) • Electronic trailer brake controller • Remote keyless entry • Remote start (requires automatic transmission) • 6-foot 4-inch box models: 31-gallon fuel tank • 8-foot box models: 32-gallon fuel tank

INTERIOR

Premium cloth 40/20/40 front bench seat • Cloth 60/40 split-folding rear bench seat • Carpet floor covering • Multistage front air bags⁽¹⁰⁾ • Supplemental side-curtain air bags⁽¹⁰⁾ • Supplemental front-seat side-mounted air bags⁽¹⁰⁾ • Leather-wrapped tilt steering wheel with audio controls • 115-volt power outlet • Automatic headlamp control • Air conditioning • Power windows and door locks • Uconnect® 5.0 AM/FM/SAT/BT touch-screen radio • Media hub with MP3 auxiliary jack, 1.5-amp and 2.5-amp USB ports • 3.5-inch Electronic Vehicle Information Center (EVIC) located in instrument panel cluster • Overhead console • Power sliding rear window

EXTERIOR

Quad lens halogen headlamps • Fog lamps • Chrome front and rear bumpers • Chrome grille surround with chrome billet inserts • Black, power heated fold-in sideview mirrors • Chrome door handles • Bed rail caps • Power locking tailgate • 4- and 7-pin trailer wiring harness/connectors • Class V trailer hitch receiver • 17-inch polished aluminum wheels with OWL tires (2500) • 17-inch chrome steel wheels (3500 DRW) • 18-inch polished aluminum wheels (3500 SRW)



OUTDOORSMAN

2500

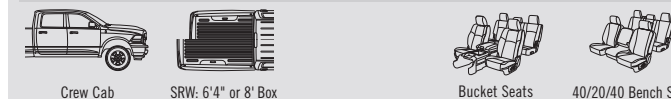

STANDARD FEATURES MECHANICAL

2500 Crew Cab 4x4 only: 5.7L HEMI V8 with heavy-duty cooling and 66RFE 6-speed automatic transmission • ESC⁽⁴⁾ system • Remote keyless entry • Electronic part-time transfer case • Electronic trailer brake controller • Transfer case skid plate • Remote start (requires automatic transmission) • Security alarm • 6-foot 4-inch box models: 31-gallon fuel tank • 8-foot box models: 32-gallon fuel tank

INTERIOR

Luxury Group • Leather-wrapped tilt steering wheel with audio controls • Premium cloth front bucket seats with center console • Power driver's seat • Cloth 60/40 split-folding rear bench • Carpet floor covering • Rubber all-weather floor mats • Multistage front air bags⁽¹⁰⁾ • Supplemental side-curtain air bags⁽¹⁰⁾ • Supplemental front-seat side-mounted air bags⁽¹⁰⁾ • Automatic headlamp control • Air conditioning • Power windows and door locks • Uconnect 8.4A AM/FM/SAT/BT/ACCESS touch-screen radio • Media hub with MP3 auxiliary jack, 1.5-amp and 2.5-amp USB ports, and SD card slot • 115-volt power outlet • Premium six-ring cluster with full-color 7-inch Multi-View Display • Overhead console with Universal Garage Door Opener • Power sliding rear window

EXTERIOR

Two-tone paint with Mineral Gray Metallic front bumper, rear bumper, and fender flares • Body-color grille surround with Black inserts • Black door handles • Black, power heated fold-in sideview mirrors with puddle lamps and turn signal indicators • Fog lamps • Quad lens halogen headlamps • Bed rail caps • Power locking tailgate • 4- and 7-pin trailer wiring harness/connectors • Class V trailer hitch receiver • Tow hooks • 17-inch forged aluminum wheels



POWER WAGON®

2500



STANDARD FEATURES MECHANICAL

2500 Crew Cab 4x4 only: 5.7L HEMI V8 with heavy-duty cooling and 66RFE 6-speed automatic transmission • 180-amp alternator • Tow hooks • Skid plates for the fuel tank and transfer case • Electronic disconnecting front stabilizer (or sway) bar • Front and rear electronic locking differentials • 4.56:1 axle ratio • 12,000-lb WARN® winch • 31-gallon fuel tank • Remote keyless entry • ESC⁽⁴⁾ system • Manual part-time transfer case • Electronic trailer brake controller

INTERIOR

Cloth front 40/20/40 bench seat • Cloth folding rear bench • Tilt steering wheel • Carpet floor covering • Multistage front air bags⁽¹⁰⁾ • Supplemental side-curtain air bags⁽¹⁰⁾ • Supplemental front-seat side-mounted air bags⁽¹⁰⁾ • Automatic headlamp control • Air conditioning • Power windows and door locks • Uconnect 5.0 AM/FM/SAT/BT touch-screen radio • Media hub with MP3 auxiliary jack, 1.5-amp and 2.5-amp USB ports • 3.5-inch EVIC located in instrument panel cluster • Overhead console • Power sliding rear window

EXTERIOR

Two-tone paint with front and rear chrome bumpers • Black wheel flares • Chrome grille surround with chrome billet inserts • Black, power heated fold-in sideview mirrors • Black door handles • Black bed rail caps • Fog lamps • Premium 70-mm projector headlamps • Premium LED taillamps • Power locking tailgate • Power Wagon Decal Package • Class V trailer hitch receiver • 4- and 7-pin trailer wiring harness/connectors • 17-inch forged aluminum wheels with 33-inch LT All-Terrain tires



LARAMIE

2500

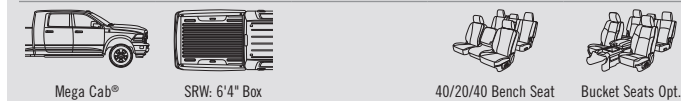
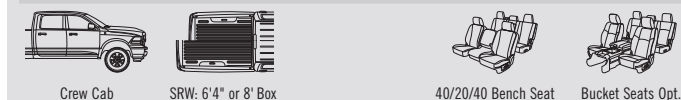

3500



STANDARD FEATURES MECHANICAL

2500: 5.7L HEMI® V8 with heavy-duty cooling and 66RFE 6-speed automatic transmission
3500 SRW: 5.7L HEMI V8 with heavy-duty cooling and 66RFE 6-speed automatic transmission • 7 x 11-inch trailer tow mirrors • Tow hooks
3500 DRW: 6.7L Cummins® Turbo Diesel with heavy-duty cooling and 6-speed manual transmission • 7 x 11-inch trailer tow mirrors • Tow hooks
2500/3500: Electronic Stability Control (ESC)⁽⁴⁾ system, which includes 4-wheel ABS, Brake Assist, Rain Brake Support, Ready Alert Braking, All-Speed Traction Control, Electronic Roll Mitigation, Hill Start Assist, and Trailer Sway Control⁽⁴⁾ • Electronic part-time transfer case (on 4x4 models) • Electronic trailer brake controller • Remote keyless entry • ParkView® Rear Back-Up Camera⁽⁶⁾ • Security alarm • 6-foot 4-inch box models: 31-gallon fuel tank • 8-foot box models: 32-gallon fuel tank

INTERIOR

Leather-trimmed heated and ventilated front 40/20/40 bench seat • Power driver and front-passenger seats • Leather-trimmed 60/40 split-folding rear bench • 115-volt power outlet • Carpet floor covering • Multistage front air bags⁽¹⁰⁾ • Supplemental side-curtain air bags⁽¹⁰⁾ • Supplemental front-seat side-mounted air bags⁽¹⁰⁾ • Heated leather-wrapped tilt steering wheel with audio controls • Automatic headlamp control • Automatic Temperature Control • Power windows and door locks • Uconnect® 8.4A AM/FM/SAT/BT/ACCESS touch-screen radio • Media hub with MP3 auxiliary jack, 1.5-amp and 2.5-amp USB ports, and SD card slot • Premium 10-speaker surround sound audio system • Premium six-ring cluster with full-color 7-inch Multi-View Display • Overhead console with Universal Garage Door Opener • Power sliding rear window

EXTERIOR

Two-tone paint treatment with lower body and wheel flares in Bright Silver Metallic • Chrome front and rear bumpers • Chrome door handles • Chrome grille surround with chrome wave inserts • Chrome, power heated fold-in sideview mirrors with puddle lamps and turn signal indicators • Premium 70-mm projector headlamps • Premium LED taillamps • Fog lamps • Bed rail caps • Power locking tailgate • 4- and 7-pin trailer wiring harness/connectors • Class V trailer hitch receiver • 17-inch polished aluminum wheels (2500/3500 DRW) • 18-inch polished aluminum wheels (3500 SRW)



POWER WAGON® LARAMIE

2500



STANDARD FEATURES MECHANICAL

2500 Crew Cab 4x4 only: 5.7L HEMI V8 with heavy-duty cooling and 66RFE 6-speed automatic transmission • 180-amp alternator • Tow hooks • Skid plates for the fuel tank and transfer case • Electronic disconnecting front stabilizer (or sway) bar • Front and rear electronic locking differentials • 4.56:1 axle ratio • 12,000-lb WARN® winch • 31-gallon fuel tank • Remote keyless entry • ESC⁽⁴⁾ system • Manual part-time transfer case • Electronic trailer brake controller • ParkView Rear Back-Up Camera⁽⁶⁾ • Security alarm

INTERIOR

Leather-trimmed heated and ventilated front 40/20/40 bench seat • Power driver and front-passenger seats • Leather-trimmed 60/40 split-folding rear bench • 115-volt power outlet • Carpet floor covering • Multistage front air bags⁽¹⁰⁾ • Supplemental side-curtain air bags⁽¹⁰⁾ • Supplemental front-seat side-mounted air bags⁽¹⁰⁾ • Heated leather-wrapped tilt steering wheel with audio controls • Automatic headlamp control • Automatic Temperature Control • Power windows and door locks • Uconnect 8.4A AM/FM/SAT/BT/ACCESS touch-screen radio • Media hub with MP3 auxiliary jack, 1.5-amp and 2.5-amp USB ports, and SD card slot • Premium 10-speaker surround sound audio system • Premium six-ring cluster with full-color 7-inch Multi-View Display • Overhead console with Universal Garage Door Opener • Power sliding rear window

EXTERIOR

Monotone paint treatment with body-color wheel flares • Chrome front and rear bumpers • Chrome door handles • Chrome grille surround with chrome wave inserts • Chrome, power heated fold-in sideview mirrors with puddle lamps and turn signal indicators • Premium 70-mm projector headlamps • Premium LED taillamps • Fog lamps • Power locking tailgate • Power Wagon tailgate badge • 4- and 7-pin trailer wiring harness/connectors • Class V trailer hitch receiver • 17-inch forged aluminum wheels with 33-inch LT All-Terrain tires



LARAMIE LONGHORN

2500



3500

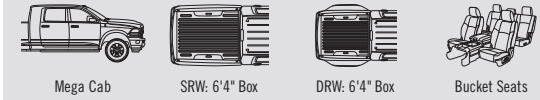
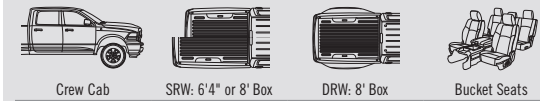

STANDARD FEATURES MECHANICAL

2500: 5.7L HEMI V8 with heavy-duty cooling and 66RFE 6-speed automatic transmission
3500 SRW: 5.7L HEMI V8 with heavy-duty cooling and 66RFE 6-speed automatic transmission • 7 x 11-inch trailer tow mirrors
3500 DRW: 6.7L Cummins Turbo Diesel with heavy-duty cooling and 68RFE 6-speed automatic transmission • 7 x 11-inch trailer tow mirrors

2500/3500: Tow hooks • ESC⁽⁴⁾ system • ParkSense® Rear Park Assist⁽⁶⁾ • ParkView Rear Back-Up Camera⁽⁶⁾ • Electronic part-time transfer case (on 4x4 models) • Electronic trailer brake controller • Remote keyless entry • Security alarm • Remote start (requires automatic transmission) • 6-foot 4-inch box models: 31-gallon fuel tank • 8-foot box models: 32-gallon fuel tank

INTERIOR

Premium leather front bucket seats • Power driver and front-passenger seats • Heated and ventilated front seats • Full-floor center console with leather console cover • 115-volt power outlet • Premium leather heated 60/40 split-folding rear bench • Carpet floor covering • Premium floor mats with removable inserts • Multistage front air bags⁽¹⁰⁾ • Supplemental side-curtain air bags⁽¹⁰⁾ • Supplemental front-seat side-mounted air bags⁽¹⁰⁾ • Heated leather-wrapped tilt steering wheel with wood accent and audio controls • Automatic headlamp control • Automatic Temperature Control • Power windows and door locks • Uconnect 8.4AN AM/FM/SAT/BT/NAV/ACCESS touch-screen radio • Media hub with MP3 auxiliary jack, 1.5-amp and 2.5-amp USB ports, and SD card slot • Premium 10-speaker surround sound audio system • Premium six-ring cluster with full-color 7-inch Multi-View Display • Overhead console with Universal Garage Door Opener • Power sliding rear window

EXTERIOR

Two-tone paint treatment with lower body, wheel flares, front bumper, rear bumper, and running boards in White Gold Metallic • Premium 70-mm projector headlamps • Premium LED taillamps • Fog lamps • Chrome grille surround with chrome wave mesh inserts • Chrome, power heated fold-in sideview mirrors with puddle lamps and turn signal indicators • Unique Laramie Longhorn badging • Chrome door handles • Black bed rail caps • Spray-in bedliner • Power locking tailgate • 4- and 7-pin trailer wiring harness/connectors • Class V trailer hitch receiver • 17-inch polished aluminum wheels (2500/3500 DRW) • 18-inch polished aluminum wheels (3500 SRW)

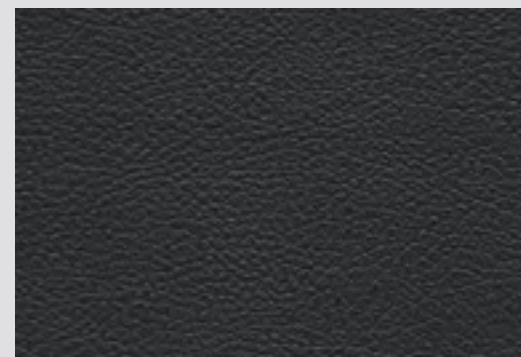

Bristol Vinyl Diesel Gray
Tradesman and Power Wagon® Tradesman

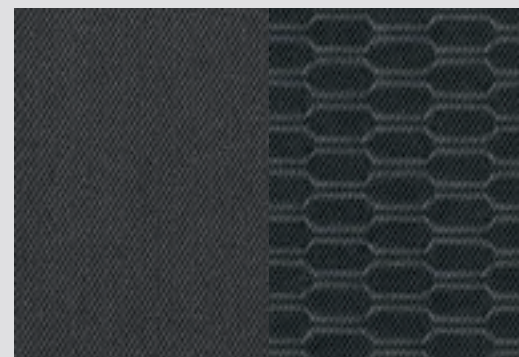

Sedoso/Embossed Alloy II on Sedoso Cloth Diesel Gray
Tradesman, Power Wagon Tradesman, SLT, and Power Wagon

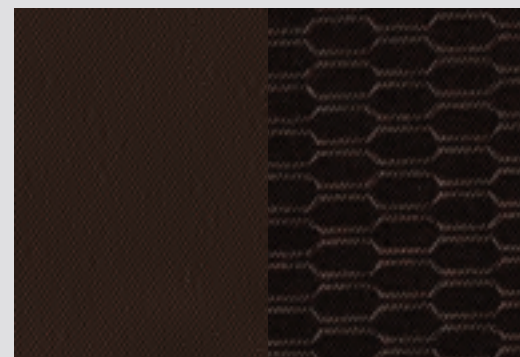

Sedoso/Embossed Alloy II on Sedoso Cloth Canyon Brown
SLT and Power Wagon

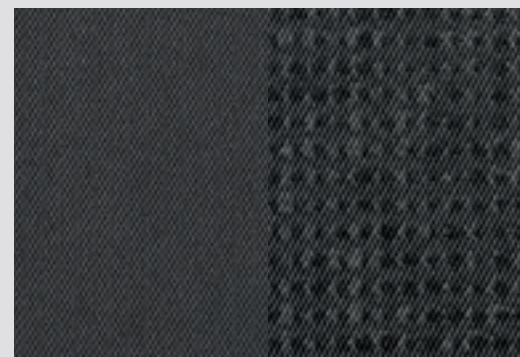

Sedoso/Carbide Cloth Diesel Gray
SLT, Big Horn/Lone Star, Outdoorsman, and Power Wagon

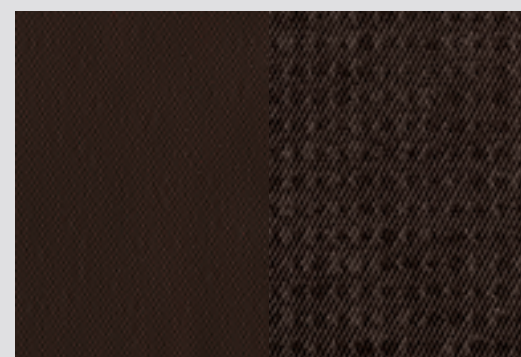

Sedoso/Carbide Cloth Canyon Brown
SLT, Big Horn/Lone Star, Outdoorsman, and Power Wagon

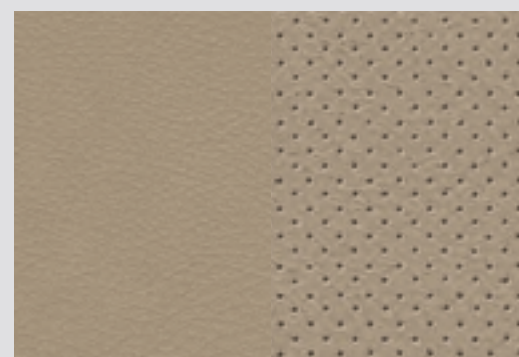

Bristol/Bristol Axis II Perforated Leather Trim Light Frost Beige
Laramie and Power Wagon Laramie



Bristol/Bristol Axis II Perforated Leather Trim Black
Laramie and Power Wagon Laramie

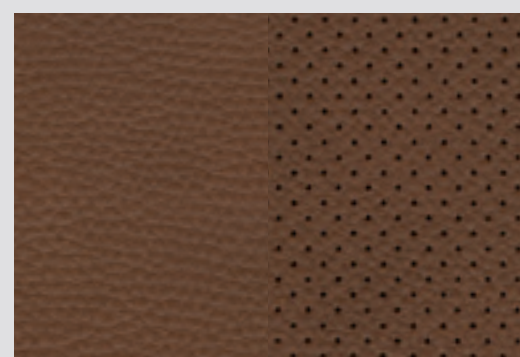

Natura Plus without Laser Etching/Natura Plus Axis II Perforated Leather Cattle Tan
Laramie Longhorn

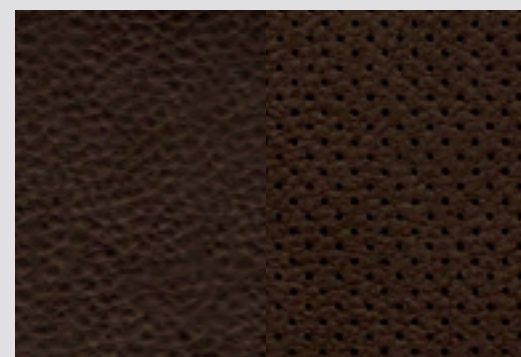

Natura Plus without Laser Etching/Natura Plus Axis II Perforated Leather Canyon Brown
Laramie Longhorn



Natura Plus with Laser Etching/Natura Plus Axis II Perforated Leather Canyon Brown
Laramie Longhorn



BLACK



BLACK GOLD PEARL



BRIGHT SILVER METALLIC



BRIGHT WHITE



COPPERHEAD PEARL



DEEP CHERRY RED CRYSTAL PEARL



FLAME RED



MAXIMUM STEEL METALLIC



MINERAL GRAY METALLIC



PRAIRIE PEARL



TRUE BLUE PEARL



WESTERN BROWN PEARL

New exterior, new interior, new technology — all matched by a stunning selection of new wheels for 2013 Ram Heavy Duty 2500/3500 models. Notable here are wheels that contribute to performance and help with fuel efficiency: the 17-inch wheels for 2500 and 3500 DRW, the 18-inch wheels standard for 3500 SRW, and the huge 20-inch wheels (late availability for 3500 SRW models).

3500 DRW WHEELS



17 x 6-inch Steel, Argent Painted Finish
Standard on Tradesman (WFU)



17 x 6-inch Steel, Chrome Finish
Standard on SLT, Big Horn/Lone Star
Available on Tradesman (WD4)



17 x 6-inch Aluminum Polished
Standard on Laramie
Available on SLT, Big Horn/Lone Star (WF7)



17 x 6-inch Aluminum Polished,
with Unique Longhorn Center Cap
Standard on Laramie Longhorn (WF9)

3500 SRW WHEELS



18 x 8-inch Full-Face Steel, Argent Painted Finish
Standard on Tradesman (WBN)



18 x 8-inch Full-Face Steel, Chrome-Clad
Standard on SLT, Available on Tradesman (WBH)



18 x 8-inch Forged Aluminum, Polished
Standard on Big Horn/Lone Star
Available on SLT (WBJ)



18 x 8-inch Cast Aluminum, Polished and Painted
Standard on Laramie (WBL)



20 x 8-inch Cast Aluminum, Silver Inserts
Late availability for SLT, Big Horn/Lone Star,
Outdoorsman, Laramie (WRJ)



18 x 8-inch Forged Aluminum
Polished and Painted, White Gold Painted Pockets
Standard on Laramie Longhorn with
Two-Tone Exterior Paint (WBM)



18 x 8-inch Forged Aluminum
Polished and Painted, Silver Painted Pockets
Standard on Laramie Longhorn with Available
Monotone Exterior Paint (WBA)



20 x 8-inch Forged Aluminum
Polished and Painted, White Gold Painted Pockets
Late availability for Laramie Longhorn with
Two-Tone Exterior Paint (WRK)



20 x 8-inch Forged Aluminum
Polished and Painted, Silver Painted Pockets
Late availability for Laramie Longhorn with
Available Monotone Exterior Paint (WRA)

2500 WHEELS



17 x 7.5-inch Steel, Argent Painted Finish
Standard on Tradesman (WD2)



17 x 8-inch Full-Face Steel, Chrome-Clad
Standard on SLT, Available on Tradesman (WGS)



17 x 8-inch Forged Aluminum, Polished
Standard on Big Horn/Lone Star, Available on SLT,
Outdoorsman (WBG)



17 x 8-inch Forged Aluminum, Polished
Standard on Power Wagon, Outdoorsman (WFF)



17 x 8-inch Forged Aluminum, Polished
Standard on Laramie, Laramie Longhorn (WFK)

2013 RAM 2500/3500 BUYER'S GUIDE

CPQS PACKAGE

	TRADSMAN REG./CREW	POWER WAGON TRADESMAN CREW	SLT REG./CREW/MEGA	BIG HORN / ONE STAR CREW/MEGA	OUTDOORSMAN CREW	POWER WAGON CREW	LARAMIE CREW/MEGA	POWER WAGON LARAMIE CREW	LARAMIE LONGHORN CREW/MEGA
2500	2TA	2TB	2TG	2TZ/2TY	2TI	2TP	2TH	2TJ	2TK
3500 SRW/DRW (6'4" Box not available with Crew Cab DRW)	X	X	X	X	X	X	X	X	X
	X/X	X/X	X/X	X/X					X/X

ENGINE/TRANSMISSION

5.7L HEMI® V8 gas engine / 6-speed automatic (66RFE; SRW only)	26A	26B	26G	26ZY	26T	26P	26H	26J	26K
5.7L CNG engine / 6-speed automatic (66RFE; 2500 Crew Cab 8' box only)	27A	—	27G	—	—	—	—	—	—
6.7L Cummins® Turbo Diesel engine / 6-speed manual (G56)	2EA	—	2EG	2EZY	2ET	—	2EH	—	—
6.7L Cummins Turbo Diesel engine / 6-speed automatic (68RFE)	2FA	—	2FG	2FZY	2FT	—	2FH	—	2FK
6.7L Cummins Turbo Diesel engine / 6-speed AISIN® HD automatic (3500 only)	28A	—	28G	28ZY	—	—	28H	—	28K
Diesel Exhaust Fluid (DEF) system (standard with diesel engine)	P	—	P	P	P	—	P	—	P

MECHANICAL FEATURES

ALTERNATOR — 160-amp (standard on gas)	S	—	S	S	S	—	S	—	S
— 180-amp (standard on diesel, included with Snowplow Prep Group on HEMI V8)	O/P	S	O/P	O/P	O/P	S	O/P	S	O/P
— 220-amp (requires diesel engine, included with Snowplow Prep Group on diesel)	O/P	—	O/P	O/P	O/P	—	O/P	—	O/P
— Dual 220-amp (3500 diesel only, late availability)	0	—	0	0	—	—	0	—	0
AXLES — Antispin rear differential (standard on 3500)	0	—	0	S	S	—	0	—	0
— Electronically locking front and rear differentials	—	S	—	—	—	S	—	S	—
— 3.42 ratio (standard for diesel)	0	—	0	0	—	—	0	—	0
— 3.73 ratio (standard for gas, available for diesel DRW)	S/O	—	S/O	S/O	S	—	S/O	—	S/O
— 4.10 ratio (optional for gas, available for diesel DRW)	—	0	—	0	0	—	0	—	0
— 4.56 ratio	—	S	—	—	—	S	—	S	—
— 10.5-inch rear axle — SRW (2500 only; requires gas engine)	S	S	S	S	S	S	S	S	S
— 11.5-inch rear axle — SRW (included with diesel engine)	P	—	P	P	P	—	P	—	P
— 11.5-inch rear axle — DRW (included with DRW 68RFE and DRW AISIN with 3.73 ratio)	—	P	—	P	—	—	P	—	P
— 11.8-inch rear axle — DRW (included with DRW AISIN with 3.73 and 4.10 ratios)	P	—	P	P	—	—	P	—	P

BATTERY — 730-amp, maintenance-free (two, required for diesel)	S	S	S	S	S	S	S	S	S
DIESEL EXHAUST BRAKE — With smart function, included with diesel engine	P	—	P	P	P	—	P	—	P
ELECTRONIC UPFITTER MODULE — Not available with premium speakers (late availability)	0	0	0	0	0	0	—	—	0
ENGINE BLOCK HEATER — Included with Cold Weather Group on diesel	O/P	0	O/P	O/P	O/P	0	O/P	0	O/P
FIFTH-WHEEL/GOOSENECK PREP PACKAGE (3500 only; not available with RamBox® System)	0	—	0	0	—	—	0	—	0

FUEL TANK — 8-gal. tank (included with CNG engine)	P	—	P	—	—	—	—	—	—
— 28-gal. tank (included with Regular Cab diesel)	P	—	P	—	—	—	—	—	—
— 31-gal. tank (included with 6'4" box)	S	S	S	S	S	S	S	S	S
— 32-gal. tank (included with 8' box; available with CNG engine)	S/O	—	S/O	S	S	—	S	—	S

SHOCKS — Front, heavy-duty	S	—	S	S	S	—	S	—	S
— Rear, heavy-duty	S	—	S	S	S	—	S	—	S
— Bilstein® — Gas-charged monotube	—	S	—	—	—	S	—	S	—

SKID PLATES (4x4) — Transfer case (included in Protection Group and Snowplow Prep Group)	P	S	P	P	S	S	P	S	P
— Fuel tank	—	S	—	—	—	S	—	S	—

STEERING — Power rack and pinion (2500 4x2 only)	S	—	S	S	S	—	S	—	S
— Power recirculating ball (2500 4x4 and 3500)	S	S	S	S	S	S	S	S	S

SUSPENSION — Three-link front suspension (3500 only)	S	—	S	S	—	—	S	—	S
— Front electronic disconnecting stabilizer bar	—	S	—	—	—	S	—	S	—
— Front stabilizer bar	S	—	S	S	S	—	S	—	S
— Rear stabilizer bar	S	—	S	S	S	—	S	—	S

TOW HOOKS — 6.7L diesel engine	S	—	S	S	S	—	S	—	S
— 5.7L gas engine (optional on 4x2; included in Protection Group on 4x4; standard on 3500)	O/P/S	S	O/P/S	O/P/S	S	S	O/P/S	S	S

TRAILER TOW — 4-pin / 7-pin trailer harness plug (combination receptacle)	S	S	S	S	S	S	S	S	S
— Class V hitch receiver	S	S	S	S	S	S	S	S	S

TRANSFER CASES (4x4 models only) — Manual shift-on-the-fly	S	S	—	—	—	S	—	S	—
— Electronic shift-on-the-fly	0	—	S	S	S	—	S	—	S

WINCH — WARN® front, electric, 12,000-lb capacity	—	S	—	—	—	S	—	S	—
— Tire carrier	S	S	S	S	S	S	S	S	S

EXTERIOR FEATURES

BEDLINER — Spray-in (not available with CNG)	0	0	0	0	0	0	0	0	S
BODY MODEL AND BOX — Regular Cab 8' box	0	—	0	—	—	—	—	—	—
— Crew Cab 6'4" box (SRW only)	0	S	0	0	0	S	0	S	0
— Crew Cab 8' box	0	—	0	0	0	—	0	—	0
— Mega Cab® 6'4" box	—	0	0	—	—	—	0	—	0

BUMPERS — Painted Black	S	—	—	—	—	—	—	—	—
— Chrome (included in Chrome Appearance Group with monotone paint)	P	S	S	S	P	S	S	S	P
— Painted	—	—	—	—	—	—	—	—	—

CLEARANCE LAMPS — Cab (included on DRW)	O/P	0	O/P	O/P	0	S	O/P	0	O/P
— Box and rear fender (included on DRW)	P	—	P	P	—	—	P	—	P

DOOR HANDLES — Black (included with low-volume paint)	S	S	P	P	S	S	—	—	—
— Chrome	—	—	S	S	—	—	S	S	S

FOG LAMPS	—	S	0	S	S	S	S	S	S
GRILLE — Black surround with Black hex	S	—	S	—	—	—	—	—	—

— Chromed surround with Black hex (included in Chrome Appearance Group)	P	—	S	—	—	—	—	—	—
— Body-color surround with Black hex	—	—	—	S	—	—	—	—	—
— Chromed surround with chrome billets	—	—	—	S	—	—	—	—	—
— Chromed surround with chrome wave-perf	—	—	—	S	—	—	—	—	—
— Chromed surround with chrome wave-mesh	—	—	—	—	—	—	—	—	S

HEADLAMPS/TAILLAMPS — Automatic headlamps	S	S	S	S	S	S	S	S	S
— Quad headlamps / incandescent taillamps	S	S	S	S	S	—	—	—	—

EXTERIOR FEATURES (CONTINUED)

— Premium projector headlamps / premium LED taillamps	—	—	—	—	—	S	S	S	S
— Auto High-Beam Headlamp Control (included in Convenience Group)	—	—	—	—	—	P	P	P	P
HEADLAMP FILLER PANEL — Black (available only with special-order paint)	0	S	0	0	0	S	—	—	—
— Body-color	S	—	S	S	S	—	S	—	S

MIRRORS — 2500 — Standard size, 6 x 9-inch	S	—	—	—	—	—	—	—	—
— Manual (Black, Regular Cab only)	S	—	—	—	—	—	—	—	—

— Power / heated (Black; included in Power and Remote Entry Group on Tradesman Regular Cab)	P/S	S	S	—	—	—	—	—	—
— Power folding / heated / puddle / turn / auto-dim (Black; included in Luxury Group)	—	—	P	P	S	P	—	—	—
— Power folding / heated / puddle / turn / auto-dim / memory (chromed)	—	—	—	—	—	S	S	S	S

2500 — Available size, 7 x 11-inch (trailer-tow mirrors, two-position fold-away with convex edge)	—	—	—	—	—	—	—	—	—
— Manual (Black, Regular Cab only)	0	0	—	—	—	—	—	—	—

— Power / heated / puddle / turn (Black, requires Power and Remote Entry Group on Tradesman Reg Cab)	0	0	0	0	0	0	—	—	—
— Power / heated / puddle / turn / memory (chromed)	—	—	—	—	—	0	0	0	0

3500 — Standard size, 7 x 11-inch (trailer-tow mirrors, two-position fold-away with convex edge)	—	—	—	—	—	—	—	—	—
— Manual (Black, Regular Cab only)	S	S	—	—	—	—	—	—	—

— Power / heated / puddle / turn (Black; included in Power and Remote Entry Group)	P	P	S	S	—	S	—	—	—
— Power / heated / puddle / turn / memory (chromed)	—	—	—	—	—	S	S	S	S

RAMBOX CARGO MANAGEMENT SYSTEM — With illuminated, lockable, drainable bins on both bed sides; stowable bed divider/extender; and cargo rail system with adjustable cleats (Short Box only, SRW only; Tradesman model requires Remote Keyless Entry; N/A with low-volume paints)	0	0	0	0	0	0	0	0	0
--	---	---	---	---	---	---	---	---	---

RUNNING BOARDS	—	—	—	—	—	—	—	—	—
— Chrome, cab-length; included with monotone Laramie Longhorn	0	—	0	0	0	—	0	—	O/P

— Chrome, wheel-to-wheel; not available on Regular Cab or DRW	0	—	0	0	0	—	0	—	0
---	---	---	---	---	---	---	---	---	---

TONNEAU COVER (not available with CNG models)	0	0	0	0	0	0	0	0	0
— Manual (Black, Regular Cab only)	S	S	—	—	—	—	—	—	—

— Power / heated / puddle / turn (Black; included in Power and Remote Entry Group)	P	P	S	S	—	S	—	—	—
— Power / heated / puddle / turn / memory (chromed)	—	—	—	—	—	S	S	S	S

WHEEL FLARES — Black	—	—	—	—	—	—	—	—	—
— Mineral Gray	—	—	—	—	S	—	—	—	—

— Bright Silver	—	—	—	—	—	S	—	—	—
— White Gold	—	—	—	—	—	—	S	—	—

— Body-color (included with monotone paint)	—	—	—	—	P	—	P	S	P
WINDSHIELD WIPERS — Variable intermittent	S	S	S	S	S	S	S	S	S

— Rain-sensitive (included in Convenience Group)	—	—	—	—	—	P	P	P	P
--	---	---	---	---	---	---	---	---	---

INTERIOR FEATURES

AIR CONDITIONING	S	S	S	S	S	S	—	—	—
AIR CONDITIONING WITH DUAL-ZONE CONTROL	—	—	—	—	—	—	S	S	S

AUXILIARY UP SWITCHES — N/A with Comfort Group, or with Uconnect® 3.0 or 5.0 radios (late availability)	0	—	0	0	0	—	0	—	0
---	---	---	---	---	---	---	---	---	---

BEZEL — Center stack	S	S	—	—	—	—	—	—	—
— Black	S	S	—	—	—	—	—	—	—

— Color-keyed	—	—	S	S	S	S	—	—	—
— Woodgrain	—	—	—	—	—	S	S	—	—

— Real wood	—	—	—	—	—	—	S	—	—
-------------	---	---	---	---	---	---	---	---	---

CIGAR LIGHTER (included in Smoker's Group)	P	P	P	P	P	P	P	P	P
CLUSTER — 3.5-inch Electronic Vehicle Information Center (EVIC)	S	S	S	—	S	—	—	—	—



2013 Ram 2500 Crew Cab Big Horn with available Cummins® Turbo Diesel shown in Deep Cherry Red Crystal Pearl. Properly secure all cargo.



[1] Class based on 350/3500 full-size pickups. [2] Class based on 250/2500 full-size pickups. [3] Class based on 250/2500 and 350/3500 full-size pickups. [4] No system, no matter how sophisticated, can repeal the laws of physics or overcome careless driving actions. Performance is limited by available traction, which snow, ice, and other conditions can affect. When the ESC warning lamp flashes, the driver needs to use less throttle and adapt speed and driving behavior to prevailing road conditions. Always drive carefully, consistent with conditions. Always wear your seat belt. [5] Transferable. See dealer for complete details and a copy of the 5-Year/100,000-Mile Powertrain Limited Warranty. [6] Always look before proceeding, electronic drive aid is not a substitute for conscientious driving, always be aware of your surroundings. [7] SiriusXM services require subscriptions, sold separately after the 12-month trial included with the new vehicle purchase. **If you decide to continue your service at the end of your trial subscription, the plan you choose will automatically renew and bill at then-current rates until you call SiriusXM at 1-866-635-2349 to cancel. See SiriusXM Customer Agreement for complete terms at www.siriusxm.com.** All fees and programming subject to change. Our satellite service is available only to those at least 18 and older in the 48 contiguous USA and D.C. Our Sirius satellite service is also available in PR (with coverage limitations). Our Internet radio service is available throughout our satellite service area and in AK and HI. © 2013 Sirius XM Radio Inc. Sirius, XM and all related marks and logos are trademarks of Sirius XM Radio Inc. [8] Requires Uconnect Phone. [9] Sold separately. Subscription required. Uconnect Web feature is not intended for use by the driver while the vehicle is in motion. Always drive carefully. [10] The Advanced Front Air Bags in this vehicle are certified to the new U.S. federal regulations for advanced air bags. Children 12 years old and younger should always ride buckled up in a rear seat. Infants in rear-facing child restraints should never ride in the front seat of a vehicle with a passenger front air bag. All occupants should always wear their lap and shoulder belts properly. [11] Always sit properly with the head restraint properly adjusted. Never place anything in front of the head restraint.

About this catalog: Since the time of printing, some of the information you'll find in this catalog may have been updated. Ask your dealer for details. Some of the equipment shown or described throughout this catalog may be available at extra cost. Specifications, descriptions, illustrative materials, and all competitive comparisons contained herein are as accurate as known at the time this publication was approved for printing. Chrysler Group LLC reserves the right to discontinue models at any time or change specifications without notice or without incurring obligation. All options are required in combination with other options. For the price of the model with the equipment you desire, or verification of specifications contained here, see your Ram dealer. AISIN is a registered trademark of Aisin Seiki Co., Ltd. Cummins is a registered trademark of Cummins, Inc. WARN is a registered trademark of Warn Industries, Inc. iPod, iPad, and iTunes are registered trademarks of Apple Inc. Bluetooth is a registered trademark of Bluetooth SIG, Inc. Bilstein is a registered trademark of August-Bilstein GmbH & Co. Sirius, XM and all related marks and logos are trademarks of Sirius XM Radio Inc. Facebook and logo are trademarks of Facebook, Inc. The Twitter logo is a service mark of Twitter, Inc. The YouTube logo is a trademark of Google Inc. NFL is a registered trademark of the National Football League. NHL is a registered trademark of the National Hockey League. MLB is a registered trademark of Major League Baseball. NASCAR is a registered trademark of the National Association for Stock Car Auto Racing, Inc. CNH, Case IH and New Holland are registered trademarks of CNH America LLC. Chrysler, Jeep, Ram, the Ram's Head logo, Big Horn, HEMI, Laramie, Laramie Longhorn, Mega Cab, Mopar, Outdoorsman, ParkSense, ParkView, Power Wagon, RamBox, Sentry Key, Tradesman, and Uconnect are registered trademarks and All-Secure, Mopar Owner Connect, and Mopar Vehicle Protection are trademarks of Chrysler Group LLC. © 2013 Chrysler Group LLC. All rights reserved.



Join fellow Ram enthusiasts and tell your story by posting comments, participating in discussions, and sharing your photos and videos. Join our community on Facebook, follow us on Twitter, and check us out on YouTube.



GO MOBILE. Take a multimedia tour of your vehicle on your mobile device. Visit the Chrysler Group LLC page in iTunes® from your smartphone or iPad® to download the most up-to-date vehicle apps. Log on to the ramtrucks.com mobile site for an at-a-glance review of what you need to know about your Ram truck. Experience visual and interactive demonstrations while gaining access to product information at your fingertips, wherever you go.

THE RAM OUTFITTER.

Owning a new 2013 Ram 2500/3500 opens up a world of new apparel, tools, and a variety of equipment for work and play. The one place to find it all is the Ram Outfitter site.

This is the online shopping center for gear and gifts for the Ram enthusiast. With the Ram identity prominently featured, you can choose from authentic wear, sports equipment, electronics, and attire. Log on. It's all at ramtrucks.com/outfitter



74-383-2315_5/13 (40M)_LITHO IN U.S.A.